

SMOKE SIGNAL

- Designed to be easy and safe to handle

Product no.: MA5000520

Application

The orange smoke signal is a small and compact distress signal for daylight use designed for stowage in liferafts and lifeboats. SOLAS requires 2 smoke signals per raft/boat.

- Signal for position marking during rescue operations
- Indicates wind direction
- Safe use on oil or petrol covered water
- Conforming to SOLAS 74 as amended
- Ideal also for leisure boats

Specifications

- Height: 114 mm (4.5 in)
- Diameter: 82 mm (3.2 in)
- Gross Weight Max. 370g (13.05 oz)
- NEC Max. 239g (8.43 oz)
- Burning time: 3 minutes minimum
- Colour of smoke: orange
- Ignition: percussion ignitor with 2 seconds safety delay

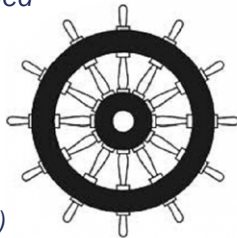

Operation

1. Remove plastic cap. Point away from body.
2. Pull tab firmly away from canister. Ensure hand remains clear of HOT END.
3. Throw Lifesmoke overboard immediately. Smoke will be emitted after a 2 second delay.

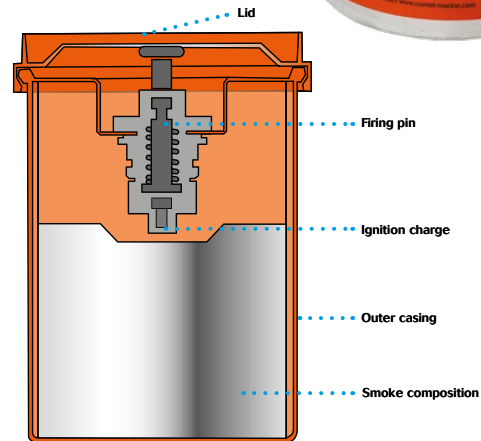
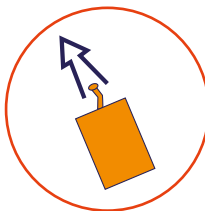
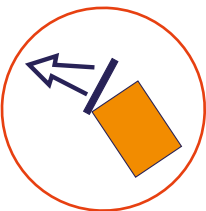

Storage

This compact unit is ideally stored in a water-resistant locker at ambient temperature allowing easy access in an emergency or in the robust, specially designed polybottle.

Approvals

Conforms to SOLAS 74 as amended, Res. MSC 81 (70). Approvals: CE 0589, BAM-P1-0191, 0589-P1-0324, BGV MED 423.008, USCG 160.122./21/0, 160.022/21/0, and other major maritime authorities worldwide.



WARNING

- Produces red hot flame - do not point at people
- Do not fire in a confined space
- Keep out of reach of children



- Only for emergency use at sea
- If damaged or dented do not use
- Do not dismantle
- Keep away from source of heat
- Do not use after expiry date

DISPOSAL

Pyrotechnics must be treated as hazardous items and must be disposed of responsibly in accordance with local regulations.